

CATALOGO
CATALOGUE
CATALOGUE

INGENIUS[®]
INNOVATION IN WATER SYSTEMS

INDOOR



LA STORIA DELLA NOSTRA AZIENDA

THE HISTORY OF OUR COMPANY - L'HISTOIRE DE NOTRE ENTREPRISE

Con oltre 40 anni di esperienza nella lavorazione dell'ottone, la nostra azienda è collocata nel comune di San Maurizio d'Opaglio (NO) a ridosso del Lago d'Orta, una piccola perla incastonata in un territorio ricco dal punto di vista industriale e naturalistico.

La grande conoscenza dei materiali, le tecnologie più avanzate di cui la nostra azienda dispone e soprattutto la voglia di circondarci di oggetti importanti, ci hanno portato alla creazione dei prodotti presentati in questo catalogo, esclusivi, originali, assolutamente "made in Italy".

La lavorazione dell'ottone e dell'acciaio avviene completamente all'interno del nostro laboratorio, utilizzando attrezzature di ultima generazione per la fresatura e la tornitura dei pezzi, per i quali partiamo da barre piene.

Estrema è l'attenzione rivolta alla scelta dei materiali, quali l'ottone e l'acciaio nelle varie tipologie e a tutti gli elementi accessori, per offrire alla nostra clientela prodotti di grande qualità.



With over 40 years of experience of brass workmanship, our company is located in Italy in the town of San Maurizio d'Opaglio (Novara) Italy, overseeing the Orta Lake, a little pearl in a territory rich of industry and nature.

The great knowledge of the materials, the most advanced technologies available in our factory and over all the desire of surrounding ourselves with important products, has allowed us to create the exclusive and original products presented in our catalogue and made in Italy.

The working of brass and steel takes place entirely in our workshop using the latest generation equipment for milling and turning of pieces for which we start from a full bar.

Extreme attention is given to the selection of the materials, like brass and steel in all its various types, and to all the accessory elements, which give us the chance to offer our clients great quality products.



Fort de plus de 40 ans d'expérience dans la transformation du laiton, notre usine est située dans la municipalité de San Maurizio d'Opaglio (NO) à côté du Lac d'Orta, une petite perle coincée dans un territoire riche sur le plan industriel et naturaliste.

La grande connaissance des matériaux, les technologies les plus avancées dont notre usine dispose et surtout l'envie de s'entourer d'objets importants, nous ont menés à la création de produits présentés dans ce catalogue, exclusifs, originaux, totalement «Made in Italy».

La transformation du laiton et de l'acier est complètement à l'intérieur de notre laboratoire, en utilisant des équipements de dernière génération pour le fraisage et le tournage des pièces, pour lesquels nous partons de la barre en laiton pleine.

Beaucoup d'attention est adressée au choix des matériaux, comme le laiton et l'acier dans les différentes typologies et à tous les éléments accessoires, pour garantir à notre clientèle des produits de très haute qualité.



INDOOR



PAG. **10**

KIT SICURACQUA



PAG. **36**

TERMOARREDI

HEATED TOWEL - RADIATEURS



PAG. **47**

Questo è il cuore di

This is the heart of
Ceci est le cœur de

IN GENIUS[®]

Pratico, semplice, geniale!

Practical, simple, ingenious!
Pratique, simple, ingénieux!

L'Attacco rapido acqua a muro universale **IN GENIUS** dotato di valvola interna con tenuta fino a 700 bar.

I VANTAGGI:

- Consente l'innesto ed il disinnesto istantaneo di tutti gli utilizzi idrici;
- Impianto idraulico sempre disponibile in pressione, evita le perdite di tempo per continui svuotamenti e riempimenti;
- Facilita le operazioni di test;
- Elimina i tappi di chiusura in fase di cantiere;
- Rosone di finitura posizionabile dopo il montaggio dell'attacco a Muro.

Universal wall bracket **IN GENIUS** with internal valve sealing tested up to 700 bar.

THE ADVANTAGES:

- Quick connection / disconnection of all water uses;
- The system is always in pressure (no waste of time caused by repeated emptying and filling);
- Quick coupling and disconnection for the test activities;
- No plugs are needed during the installation phase;
- Finishing rosette to be positioned after the installation of the wall fittings, with the associated benefits.

La prise murale universelle **IN GENIUS** dispose d'un clapet interne avec étanchéité jusqu'à plus de 700 BAR.

AVANTAGES:

- Permet la connexion et la déconnexion rapide de toutes les fonctions liées à l'eau;
- Le système est toujours sous pression (pas de perte de temps causée par la vidange et les remplissages répétés);
- Facilite les test;
- Aucun bouchon n'est nécessaire pendant la phase de chantier et de montage;
- La rosace de finition peut être placée après l'installation du raccord au mur, avec les avantages associés **IN GENIUS**.



Bagno
Bathroom
Salle de bains

Cucina
Kitchen
Cuisine

Locale tecnico
Technical room
Local technique

Riscaldamento
Heating
Chauffage

Giardino
Garden
Jardin

Il primo ed unico sistema al mondo che rivoluziona l'utilizzo dell'acqua

Sistema inGENIUS® è una **innovativa tecnologia** brevettata da SG, realizzata grazie all'esperienza pluridecennale nella progettazione e realizzazione di componenti per l'idraulica nell'edilizia residenziale.

inGENIUS® quindi è la valvola che, grazie all'aggancio e lo sgancio rapido dei punti acqua, permette a chi realizza impianti di **velocizzare le operazioni di installazione e collaudo in pressione**, evitando il montaggio dei tappi provvisori e **lo svuotamento** durante l'installazione di sanitari e rubinetteria.

Questo sistema di innesto universale si apprezza anche

in caso di perdite d'acqua dai rubinetti o dai flessibili, in attesa della riparazione è sufficiente staccare l'innesto e l'acqua automaticamente si ferma lasciando l'impianto in pressione e perfettamente utilizzabile.



The first and only system in the world that revolutionizes the use of water

*The inGENIUS system is an **innovative technology** patented by SG, created thanks to decades of experience in the design and manufacture of components for plumbing in residential buildings.*

*inGENIUS is the valve that, with the quick coupling and release of the water points, allows those who make plumbing systems **to speed up installation and pressure testing operations**, avoiding the assembly of temporary "plug for test facility" and **the emptying** of the system during installation of sanitary ware and taps.*

*This universal coupling system is also appreciated in the **event of water leaks** from the taps or connection hoses, while waiting for the repair it is sufficient to disconnect the coupling and the water automatically stops leaving the system in pressure and perfectly usable.*

Le premier et seul système au monde qui révolutionne l'utilisation de l'eau

Le système inGENIUS est une technologie innovante brevetée par SG, créée grâce à des décennies d'expérience dans la conception et la fabrication de composants pour la plomberie dans les bâtiments résidentiels.

inGENIUS est la vanne qui, avec **arrêt instantané de l'eau pour une déconnexion rapide** de son raccord, permet à ceux qui fabriquent des systèmes de plomberie pour **accélérer les opérations d'installation** et de test de pression, en évitant le montage d'un **"bouchon pour banc d'essai"** temporaire et la **vidange du système** lors de l'installation de sanitaires et robinetterie.

Ce système de raccord universel est également apprécié en cas de **fuites d'eau au niveau des robinets** ou des durites de raccordement, en attendant la réparation, il suffit de débrancher le raccord et l'eau cesse automatiquement de sortir du système en pression et parfaitement utilisable.



There will no longer be ONLY electrical sockets in our homes!

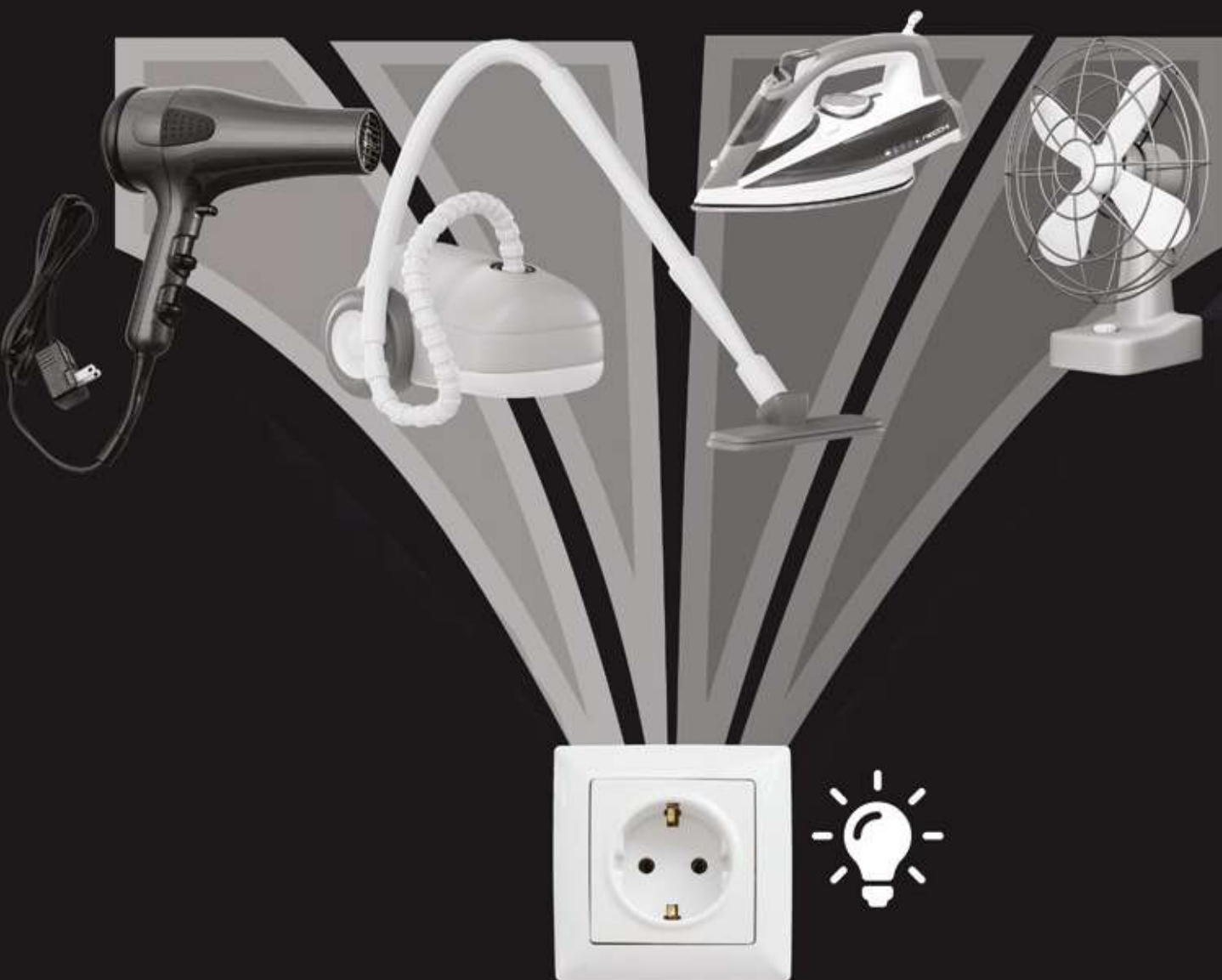

Nelle nostre case non ci saranno più SOLO placchette elettriche!

INFORMAZIONI TECNICHE E AVVERTENZE

TECHNICAL INFORMATION AND ADVICE - RENSEIGNEMENTS TECHNIQUES ET AVERTISSEMENTS

Pressione di utilizzo

Water pressure usage
Pression d'exercice

0 ÷ 10 bar

Temperatura di utilizzo

Temperature usage
Température d'exercice

5 ÷ 90°C

Liquidi a contatto

Liquid contact
Liquides à contact

Acqua

Water
Eau

Campo di impiego

Usage sector
Domaine d'application

Settore idrotermosanitario

Sanitary plumbing
Secteur hydro thermo sanitaire

Portata con pressione di linea

Water supply with line pressure
Débit d'eau avec pression de conduite

α 3 BAR: 30 LITRI AL MINUTO / α 2 BAR: 24 LITRI AL MINUTO
AT 3 BAR: 30 LITRES A MINUTE / AT 2 BAR: 24 LITRES A MINUTE
à 3 BAR: 30 LITRES PAR MINUTE / à 2 BAR: 24 LITRES PAR MINUTE

CHANGE THE WAY YOU THINK ABOUT WATER

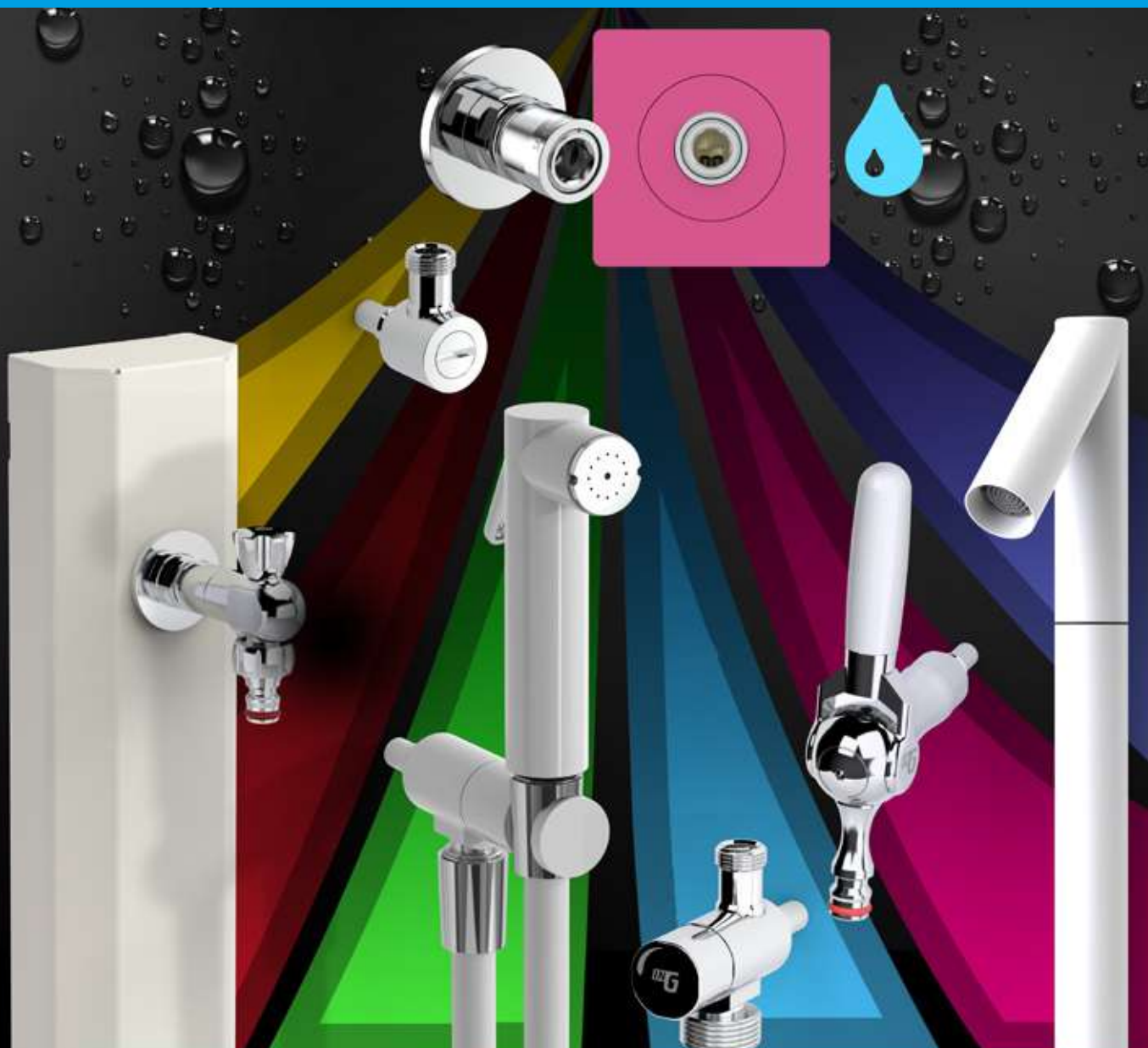

CAMBIA IL MODO DI PENSARE ALL'ACQUA

IT Sistema inGENIUS introduce un concetto innovativo che rivoluziona il modo di concepire gli impianti idraulici.

Grazie all'adozione dello sgancio rapido, il controllo del flusso d'acqua diventa un'operazione intuitiva e veloce, simile all'uso di un interruttore in un impianto elettrico.

Questa soluzione non solo semplifica la gestione dell'acqua, ma trasforma radicalmente il paradigma tradizionale dell'impianto idraulico.

La nostra visione è quella di offrire un'esperienza all'utilizzatore più efficiente e moderna, ridefinendo il modo in cui ci rapportiamo e interagiamo con gli impianti idraulici.

EN The inGENIUS system introduces an innovative concept that could revolutionise the way plumbing systems are conceived.

Thanks to the adoption of quick disconnect, controlling water flow becomes an intuitive and fast operation, similar to using a switch in an electrical system.

This solution not only simplifies water management, but also radically transforms the traditional plumbing paradigm.

Our vision is to offer a more efficient and modern user experience, redefining the way we relate and interact with plumbing systems.

FR Le système inGENIUS introduit un concept innovant qui pourrait révolutionner la façon dont les systèmes de plomberie sont conçus.

Grâce à l'adoption d'un système de déconnexion rapide, le contrôle du débit d'eau devient une opération intuitive et rapide, similaire à l'utilisation d'un interrupteur dans un système électrique.

Cette solution ne simplifie pas seulement la gestion de l'eau, mais transforme aussi radicalement le paradigme traditionnel de la plomberie.

Notre vision est d'offrir une expérience utilisateur plus efficace et plus moderne, en redéfinissant la façon dont nous sommes en relation et interagissons avec les systèmes de plomberie.



IN GENIUS[®]
INNOVATION IN WATER SYSTEMS

INDOOR

Attacco rapido acqua in ottone cromato per connessioni con flessibile
 Brass chrome plated rapid fitting for hoses connection
 Raccord rapide eau en laiton chromé pour connexion flexible



IG110RF-3/8G

IG108N-3/8G

IDEALE PER
 PERFECT FOR
 IDÉAL POUR

attacco bidet
 bidet connection
 raccord pour bidet



Cod.	Note
IG100R-3/8G	Innesto 3/8" G senza filtro - 3/8" G connection without filter - Greffe 3/8" G sans filtre
IG110RF-3/8G	Innesto 3/8" G con filtro - 3/8" G connection with filter - Greffe 3/8" G avec filtre
IG108N-3/8G	Innesto 3/8" G senza filtro e senza rosone - 3/8" G connection without rosette and filter - Greffe 3/8" G sans filtre et sans rosace

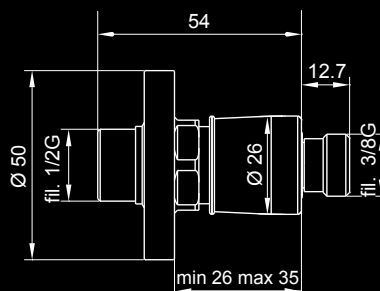



Attacco rapido acqua in ottone cromato per connessioni con flessibile
Brass chrome plated rapid fitting for hoses connection
 Raccord rapide eau en laiton chromé pour connexion flexible



IDEALE PER
PERFECT FOR
IDÉAL POUR

IG110RF-1/2G

IG108N-1/2G



attacco bidet
bidet connection
 raccord pour bidet

Cod.	Note
IG100R-1/2G	Innesto 1/2" G senza filtro - 1/2" G connection without filter - Greffe 1/2" G sans filtre
IG110RF-1/2G	Innesto 1/2" G con filtro - 1/2" G connection with filter - Greffe 1/2" G avec filtre
IG108N-1/2G	Innesto 1/2" G senza filtro e senza rosone - 1/2" G connection without rosette and filter - Greffe 1/2" G sans filtre et sans rosace

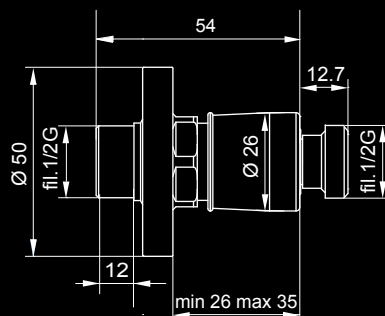



Attacco rapido acqua in ottone cromato per connessioni con flessibile

Brass chrome plated rapid fitting for hoses connection

Raccord rapide eau en laiton chromé pour connexion flexible



IG110RF-3/4G

IG108N-3/4G

IDEALE PER
PERFECT FOR
IDÉAL POUR

**attacco diretto lavatrice/
lavastoviglie**

*washing machine/dishwasher direct
connection*

raccord direct lave-linge/lave-vaisselle



Cod.	Note
IG100R-3/4G	Innesto 3/4"G senza filtro - 3/4"G connection without filter - Greffe 3/4"G sans filtre
IG110RF-3/4G	Innesto 3/4"G con filtro - 3/4"G connection with filter - Greffe 3/4"G avec filtre
IG108N-3/4G	Innesto 3/4"G senza filtro e senza rosone - 3/4"G connection without rosette and filter - Greffe 3/4"G sans filtre et sans rosace

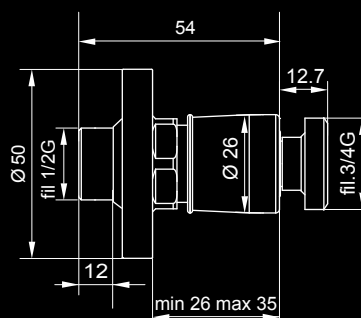

IG112R-1/2GF

INDOOR



Attacco rapido acqua in ottone cromato per connessioni con flessibile

Brass chrome plated rapid fitting for hoses connection

Raccord rapide eau en laiton chromé pour connexion flexible



IDEALE PER
PERFECT FOR
IDÉAL POUR

IG118N-1/2GF

attacco caldaia/boiler

boiler connection

raccord chaudière



Cod.	Note
IG112R-1/2GF	Innesto 1/2" G Femmina senza filtro - 1/2" G Female connection without filter Grefe 1/2" G Fem. sans filtre
IG118N-1/2GF	Innesto 1/2" G Femmina senza filtro e senza rosone - 1/2" G female connection without filter and rosette - Grefe 1/2" G Fem. sans filtre et sans rosace

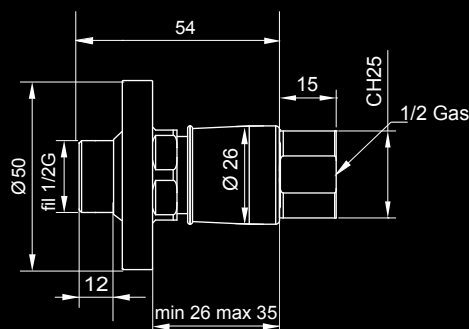



Attacco rapido acqua in ottone cromato per connessioni con flessibile

Brass chrome plated rapid fitting for hoses connection

Raccord rapide eau en laiton chromé pour connexion flexible



IDEALE PER
PERFECT FOR
IDÉAL POUR

IG118N-3/4GF

attacco caldaia/boiler

boiler connection

raccord chaudière



Cod.	Note
IG112R-3/4GF	Innesto 3/4" G Femmina senza filtro - <i>3/4" G Female connection without filter</i> Grefe 3/4" G Fem. sans filtre
IG118N-3/4GF	Innesto 3/4" G Femmina senza filtro e senza rosone - <i>3/4" G female connection without filter and rosette</i> - Grefe 3/4" G Fem. sans filtre et sans rosace

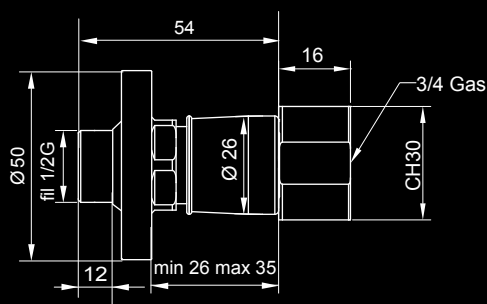

IG100R-3/8G 45°

INDOOR

Attacco rapido acqua in ottone cromato per connessioni con flessibile
 Brass chrome plated rapid fitting for hoses connection
 Raccord rapide eau avec sicurvetta en laiton chromé pour connexion flexible



IG110RF-3/8G 45°

IG108N-3/8G 45°

IDEALE PER
 PERFECT FOR
 IDÉAL POUR

attacco sottolavabo/bidet
 under washbasin/bidet
 connection
 raccord sous lavabo/bidet



Cod.	Note
IG100R-3/8G 45°	Innesto 3/8" G <i>SICURVETTA</i> 45° senza filtro - 3/8" G connection with <i>SICURVETTA</i> 45° without filter - Greffe 3/8" G avec <i>SICURVETTA</i> 45° sans filtre
IG110RF-3/8G 45°	Innesto 3/8" G con <i>SICURVETTA</i> 45° e filtro - 3/8" G connection with <i>SICURVETTA</i> 45° and filter - Greffe 3/8" G avec <i>SICURVETTA</i> 45° et avec filtre
IG108N-3/8G 45°	Innesto 3/8" G con <i>SICURVETTA</i> 45° senza rosone e senza filtro - 3/8" G connection with <i>SICURVETTA</i> 45° without filter and rosette - Greffe 3/8" G avec <i>SICURVETTA</i> 45° sans filtre et sans rosace

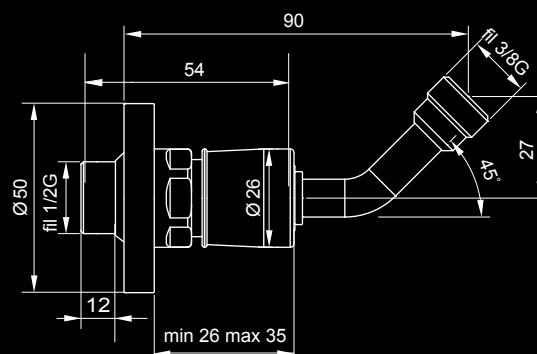



Attacco rapido acqua ottone cromato per connessioni con flessibile

Brass chrome plated rapid fitting for hoses connection

Raccord rapide eau avec sicurvetta en laiton chromé pour connexion flexible



IG110RF-3/8G 90°

IG108N-3/8G 90°

IDEALE PER
PERFECT FOR
IDÉAL POUR



attacco sottolavabo/bidet

under washbasin/bidet connection

raccord sous lavabo/bidet

Cod.	Note
IG100R-3/8G 90°	Innesto 3/8" G <i>SICURVETTA</i> 90° senza filtro - 3/8" G connection with <i>SICURVETTA</i> 90° without filter - Greffe 3/8" G avec <i>SICURVETTA</i> 90° sans filtre
IG110RF-3/8G 90°	Innesto 3/8" G con <i>SICURVETTA</i> 90° e filtro - 3/8" G connection with <i>SICURVETTA</i> 90° and filter - Greffe 3/8" G avec <i>SICURVETTA</i> 90° et avec filtre
IG108N-3/8G 90°	Innesto 3/8" G con <i>SICURVETTA</i> 45° senza rosone e senza filtro - 3/8" G connection with <i>SICURVETTA</i> 45° without filter and rosette - Greffe 3/8" G avec <i>SICURVETTA</i> 45° sans filtre et sans rosace

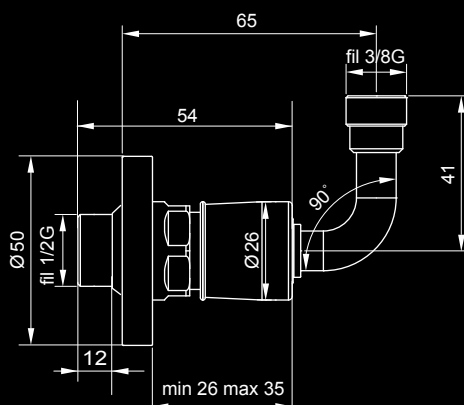



Attacco rapido acqua ottone cromato per connessioni con flessibile

Brass chrome plated rapid fitting for hoses connection

Raccord rapide eau avec sicurvetta en laiton chromé pour connexion flexible



IG110RF-1/2G 90°

IG108N-1/2G 90°

IDEALE PER
PERFECT FOR
IDÉAL POUR

attacco sottolavabo/bidet

under washbasin/bidet
connection

raccord sous lavabo/bidet



Cod.	Note
IG100R-1/2G 90°	Innesto 1/2" G <i>SICURVETTA</i> 90° senza filtro - 1/2" G connection with <i>SICURVETTA</i> 90° without filter - Greffe 1/2" G avec <i>SICURVETTA</i> 90° sans filtre
IG110RF-1/2G 90°	Innesto 1/2" G con <i>SICURVETTA</i> 90° e filtro - 1/2" G connection with <i>SICURVETTA</i> 90° and filter - Greffe 1/2" G avec <i>SICURVETTA</i> 90° et avec filtre
IG108N-1/2G 90°	Innesto 1/2" G con <i>SICURVETTA</i> 45° senza rosone e senza filtro - 1/2" G connection with <i>SICURVETTA</i> 45° without filter and rosette - Greffe 1/2" G avec <i>SICURVETTA</i> 45° sans filtre et sans rosace

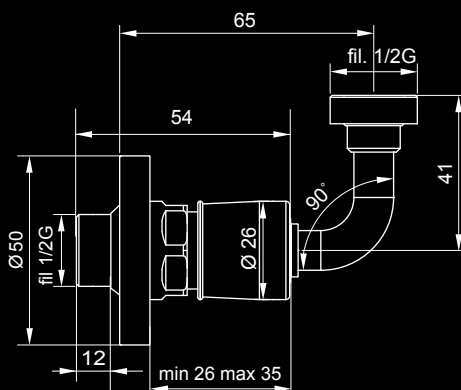



Attacco rapido acqua in ottone cromato per connessioni con flessibile
Brass chrome plated rapid fitting for hoses connection
 Raccord rapide eau en laiton chromé pour connexion flexible



IDEALE PER
PERFECT FOR
IDÉAL POUR

IG101E-1/2

attacco sottolavabo/bidet
under washbasin/bidet connection
 raccord sous lavabo/bidet



Cod.	Note
IG101E	Innesto 3/8" G con filtro in acciaio inox e valvola di non ritorno - 3/8" G connection with inox filter and check valve - Greffe 3/8" G avec filtre en acier inox et soupape antiretour
IG101E-1/2	Innesto 1/2" G con filtro in acciaio inox e valvola di non ritorno - 1/2" G connection with inox filter and check valve - Greffe 1/2" G avec filtre en acier inox et soupape antiretour

IG101E

IG101E-1/2

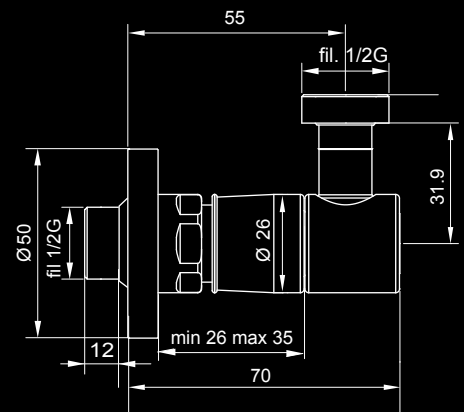
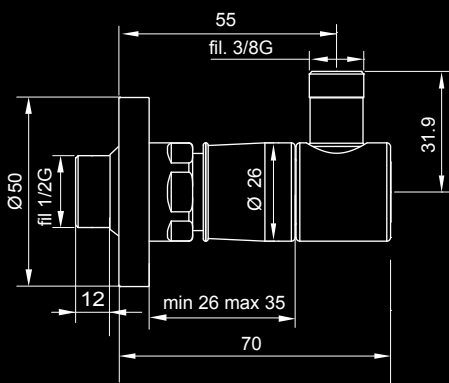

IG101R

INDOOR

NEW



Attacco rapido acqua in ottone cromato per sottolavabo/bidet MINIMAL con filtro per connessioni tubo rame Ø10 mm o flessibile

Brass chrome plated rapid fitting MINIMAL angle valve for under washingbasin/bidet with filter and copper pipe Ø10 mm or hoses connection

Raccord rapide eau robinet d'équerre MINIMAL avec raccord sous lavabo/bidet et filtre en laiton chromé pour connexion tuyau en cuivre Ø10 mm ou flexible



IDEALE PER
PERFECT FOR
IDÉAL POUR

IG201S



attacco sottolavabo/bidet

under washbasin/bidet connection

raccord sous lavabo/bidet

Cod.	Note
IG101R	Innesto 3/8"G con filtro in acciaio inox e valvola di non ritorno - 3/8"G connection with inox filter and check valve - Greffe 3/8"G avec filtre en acier inox et soupape antiretour
IG201S	Innesto 3/8"G con filtro in acciaio inox e valvola di non ritorno - 3/8"G connection with inox filter and check valve - Greffe 3/8"G avec filtre en acier inox et soupape antiretour

IG101R

IG201S

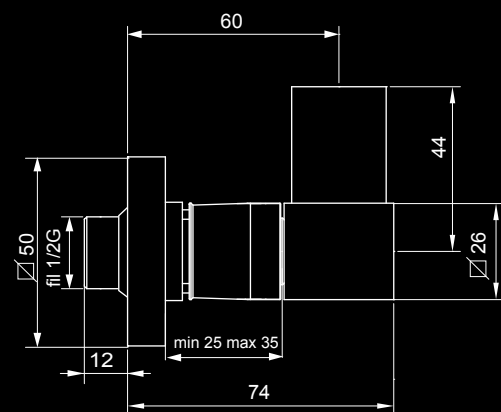
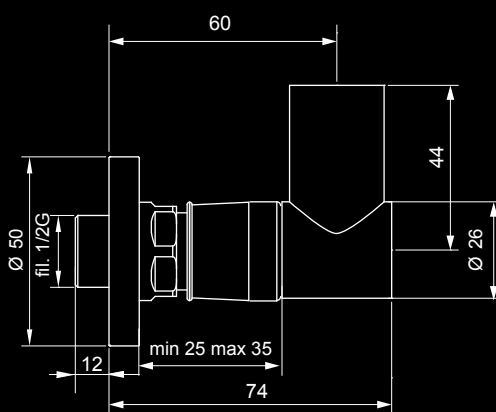



Attacco rapido acqua (lavastoviglie e lavello) in ottone cromato per connessioni con flessibile

Brass chrome plated rapid fitting (under-sink/dishwasher) for hoses connection

Raccord rapide eau (évier/lave-vaisselle) en laiton chromé pour connexion flexible



IDEALE PER
PERFECT FOR
IDÉAL POUR

IG106RAL



attacco sottolavello/
lavastoviglie

under-sink/dishwasher
connection

raccord sous l'évier/
le lave-vaisselle

Cod.	Note
IG103RAL	Innesto 3/8" G e 3/4" G con filtro in acciaio inox e valvola di non ritorno - 3/8" G and 3/4" G connection with inox filter and check valve - Greffe 3/8" G et 3/4" G avec filtre en acier inox et soupape antiretour
IG106RAL	Innesto 1/2" G e 3/4" G con filtro in acciaio inox - 1/2" G and 3/4" G connection with inox filter - Greffe 1/2" G et 3/4" G avec filtre en acier inox

IG103RAL

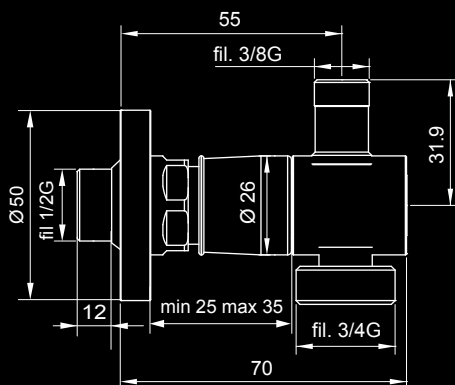

IG106RAL

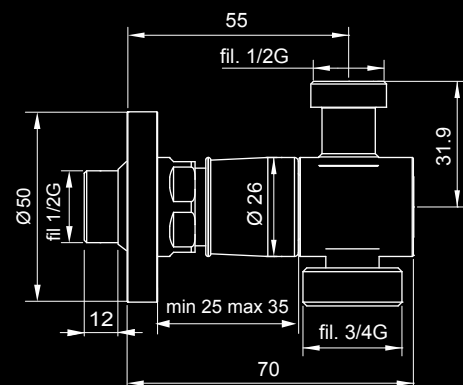



Attacco rapido acqua 2 vie (lavastoviglie e lavello) in ottone cromato per connessioni con flessibile con vitone ceramico

Brass chrome plated 2 way rapid fitting (under-sink/dishwasher) for hoses connection with ceramic head

Raccord rapide eau 2 voies (évier/lave-vaisselle) en laiton chromé pour connexion flexible avec valve céramique



**IDEALE PER
PERFECT FOR
IDÉAL POUR**

IG106RALS



**attacco sottolavello/
lavastoviglie**
*under-sink/dishwasher
connection*

**raccord sous l'évier/
le lave-vaisselle**

Cod.	Note
IG103RALS	Innesto 2 vie 3/8" G e 3/4" G per lavastoviglie con vitone ceramico - 3/8" G and 3/4" G dishwasher connection with ceramic head - Greffe 2 voies 3/8" G et 3/4" G pour lave-vaisselle avec ouvrage de tête à disque en céramique
IG106RALS	Innesto 2 vie 1/2" G e 3/4" G per lavastoviglie con vitone ceramico - 1/2" G and 3/4" G dishwasher connection with ceramic head - Greffe 2 voies 1/2" G et 3/4" G pour lave-vaisselle avec ouvrage de tête à disque en céramique

IG103RALS

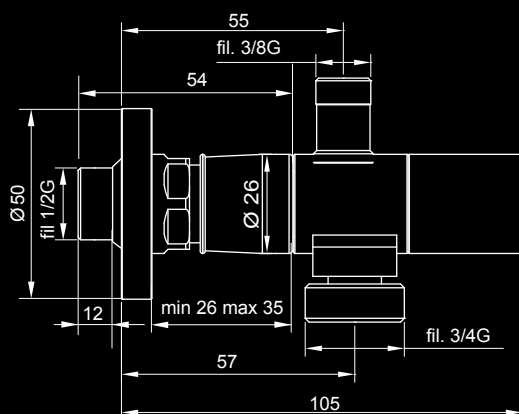

IG106RALS

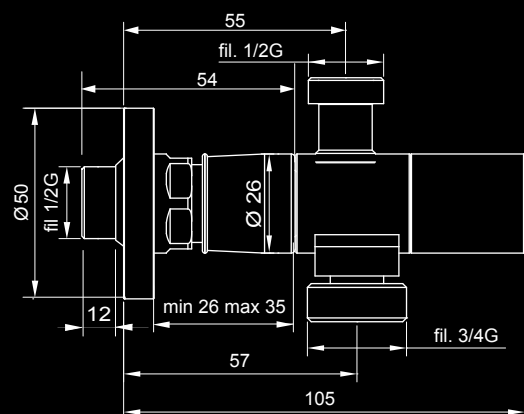



Attacco rapido acqua eccentrico 3/4" M economy in ottone cromato

Eccentric brass chrome plated 3/4" M economy rapid fitting for external groups

Raccord rapide eau excentrique 3/4" M economy pour groupes extérieurs en laiton chromé



IDEALE PER
PERFECT FOR
IDÉAL POUR

attacco gruppi esterni

connection for external groups

raccord pour les groupes
externes

Cod.	Note
IG132ER	Eccentricità - <i>Eccentricity</i> - Excentricité 5.5mm

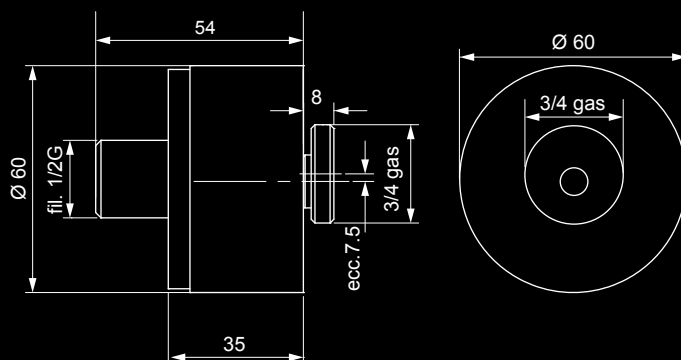



Attacco rapido acqua eccentrico 3/4M in ottone cromato con filtro

Eccentric brass chrome plated 3/4M rapid fitting with filter

Raccord rapide eau excentrique 3/4M en laiton chromé avec filtre



IDEALE PER
PERFECT FOR
IDÉAL POUR

attacco gruppi esterni

connection for external groups

raccord pour les groupes externes

Cod.	Note
IG102ER	Eccentricità - <i>Eccentricity</i> - Excentricité 7.5mm

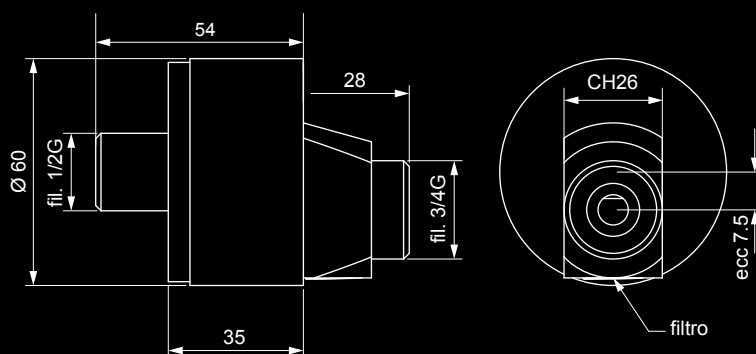



Attacco rapido acqua SWISS in ottone cromato CALOTTA FISSA

Brass chrome plated SWISS rapid fitting FIXED NUT

Raccord rapide eau SWISS en laiton chromé CALOTTE FIXE



IDEALE PER
PERFECT FOR
IDÉAL POUR

IG145ER



attacco gruppi esterni

connection for external groups

raccord pour les groupes
externes

Cod.	Note
IG140ER	Calotta fissa 1/2" F gas in ottone cromato - Brass chrome plated 1/2" F gas nut - Calotte fixe 1/2" F en laiton chromé
IG145ER	Calotta fissa 3/4" F gas in ottone cromato - Brass chrome plated 3/4" F gas nut - Calotte fixe 3/4" F en laiton chromé

IG140ER

IG145ER

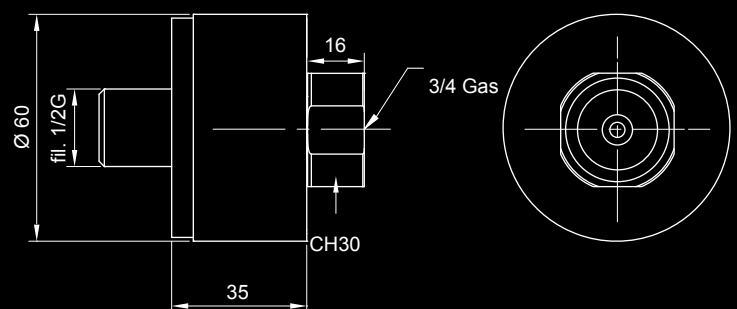
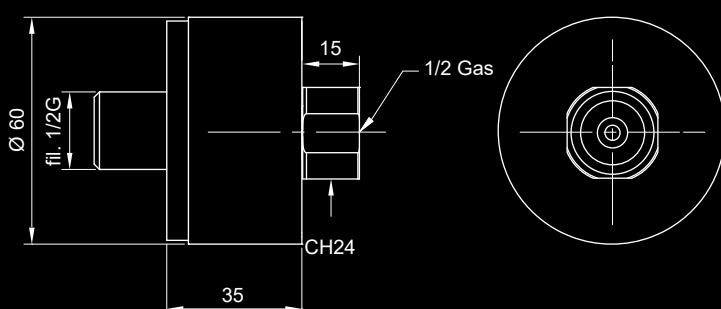



Attacco rapido acqua SWISS in ottone cromato CALOTTA ECCENTRICA
Brass chrome plated SWISS rapid fitting EXCENTRIC NUT
 Raccord rapide eau SWISS en laiton chromé CALOTTE ECCENTRIQUE



IDEALE PER
PERFECT FOR
IDÉAL POUR

IG155ER



attacco gruppi esterni
connection for external groups
 raccord pour les groupes
 externes

Cod.	Note
IG150ER	Calotta eccentrica 1/2" F gas in ottone cromato - Brass chrome plated eccentric 1/2" F gas nut - Calotte excentrique 1/2" F gas en laiton chromé
IG155ER	Calotta eccentrica 3/4" F gas in ottone cromato - Brass chrome plated eccentric 3/4" F gas nut - Calotte excentrique 3/4" F gas en laiton chromé

IG150ER

IG155ER

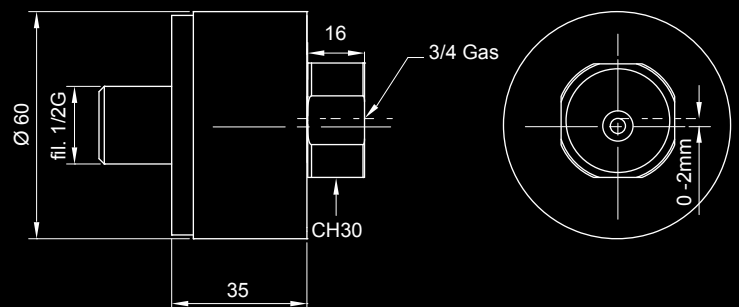
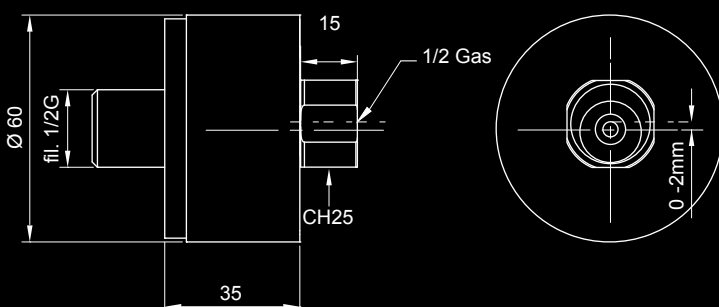

IG103RDA

INDOOR

NEW



Attacco rapido acqua MINIMAL 1 via in ottone cromato per connessioni con flessibile

Brass chrome plated 1 way MINIMAL rapid fitting for hoses connection

Raccord rapide eau 1 voie MINIMAL en laiton chromé pour connexion flexible



IDEALE PER
PERFECT FOR
IDÉAL POUR

IG803SDA

NEW

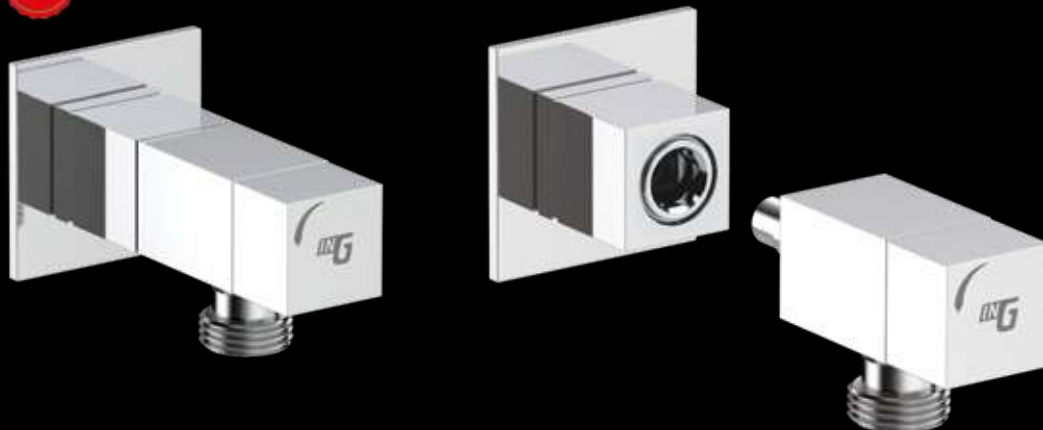

rubinetto ad angolo

angle valve

robinet d'angle

Cod.	Note
IG103RDA	Innesto 1 via 1/2" G per connessione doccetta con vitone ceramico - 1/2" G handshower connection with ceramic head - Greffe 1 voie 1/2" G pour connexion douchette avec ouvrage de tête à disque en céramique
IG803SDA	Innesto 1 via 1/2" G per connessione doccetta con vitone ceramico - 1/2" G handshower connection with ceramic head - Greffe 1 voie 1/2" G pour connexion douchette avec ouvrage de tête à disque en céramique

IG103RDA

IG803SDA

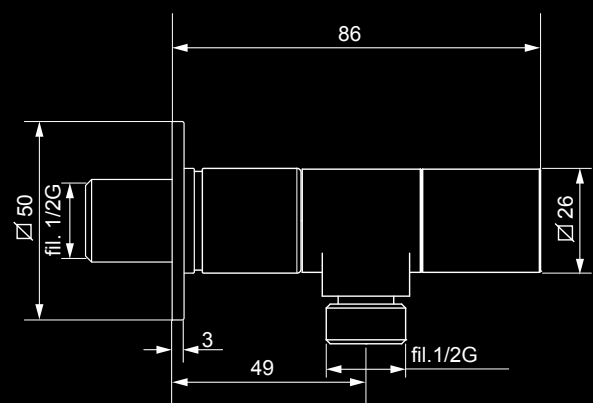
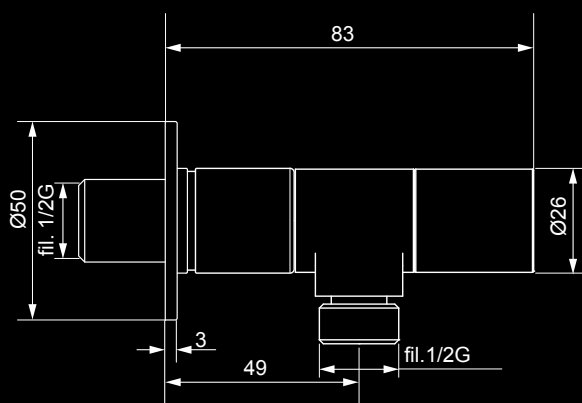



Attacco rapido acqua MINIMAL 1 via (lavatrice) in ottone cromato per connessioni con flessibile

Brass chrome plated 1 way (washing machine) rapid fitting for hoses connection

Raccord rapide eau 1 voie (machine à laver) en laiton chromé pour connexion flexible



IDEALE PER
PERFECT FOR
IDÉAL POUR

IG803SGA

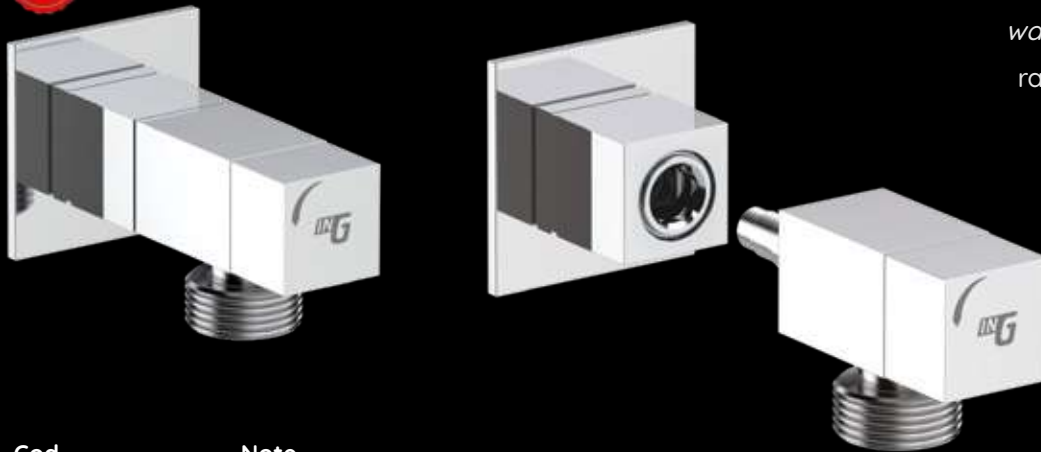

attacco lavatrice
washing machine connection
raccord pour machine à laver

Cod.	Note
IG103RGA	Innesto 1 via 3/4" G per connessione doccetta con vitone ceramico - 3/4" G handshower connection with ceramic head - Greffe 1 voie 3/4" G pour connexion douchette avec ouvrage de tête à disque en céramique
IG803SGA	Innesto 1 via 3/4" G per connessione doccetta con vitone ceramico - 3/4" G handshower connection with ceramic head - Greffe 1 voie 3/4" G pour connexion douchette avec ouvrage de tête à disque en céramique

IG103RGA

IG803SGA

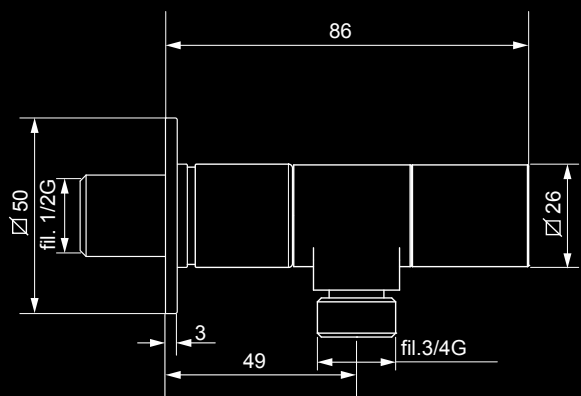
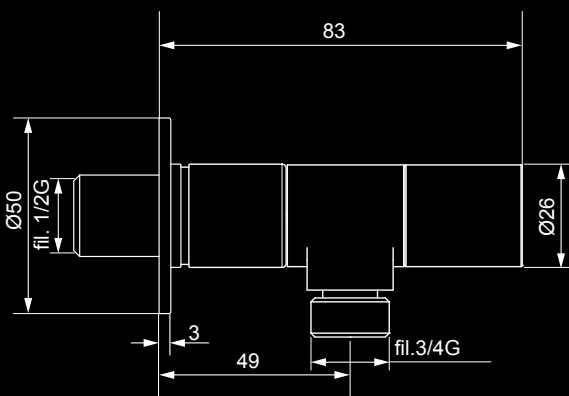

IG702R

INDOOR



Attacco rapido acqua MINIMAL in ottone cromato con attacco flessibile 1/2" G e porta doccetta FISSO con protezione antigraffio

Brass chrome plated MINIMAL rapid fitting with 1/2" G shower hose connection and FIXED shower holder with scratch protection

Raccord rapide MINIMAL en laiton chromé avec raccord pour flexible de douche 1/2" G et support de douche FIXE avec protection contre les griffes



IDEALE PER
PERFECT FOR
IDÉAL POUR

IG802S



porta doccetta

shower holder

support de douche



Cod.	Note
IG702R	-
IG802S	-

IG702R

IG802S

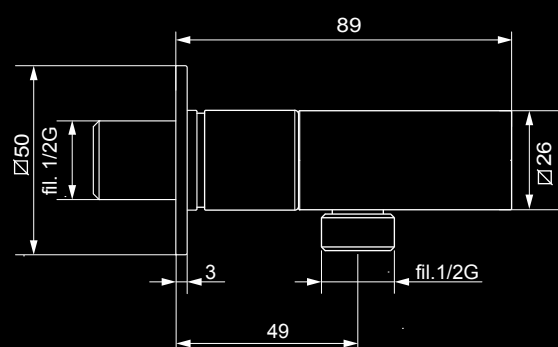
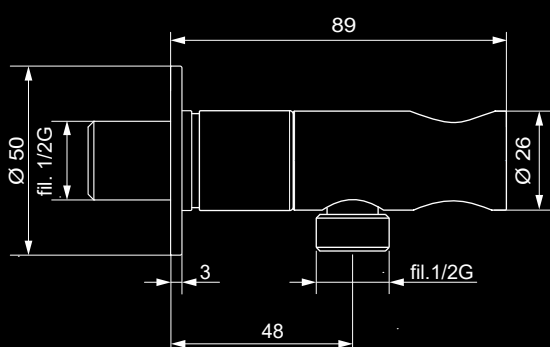



Attacco rapido acqua MINIMAL in ottone cromato con attacco flessibile 1/2" G e porta doccetta REGOLABILE con protezione antigraffio

Brass chrome plated MINIMAL rapid fitting with 1/2" G shower hose connection and ADJUSTABLE shower holder with scratch protection

Raccord rapide MINIMAL en laiton chromé avec raccord pour flexible de douche 1/2" G et support de douche ADJUSTABLE avec protection contre les griffes



IDEALE PER
PERFECT FOR
IDÉAL POUR

IG805S

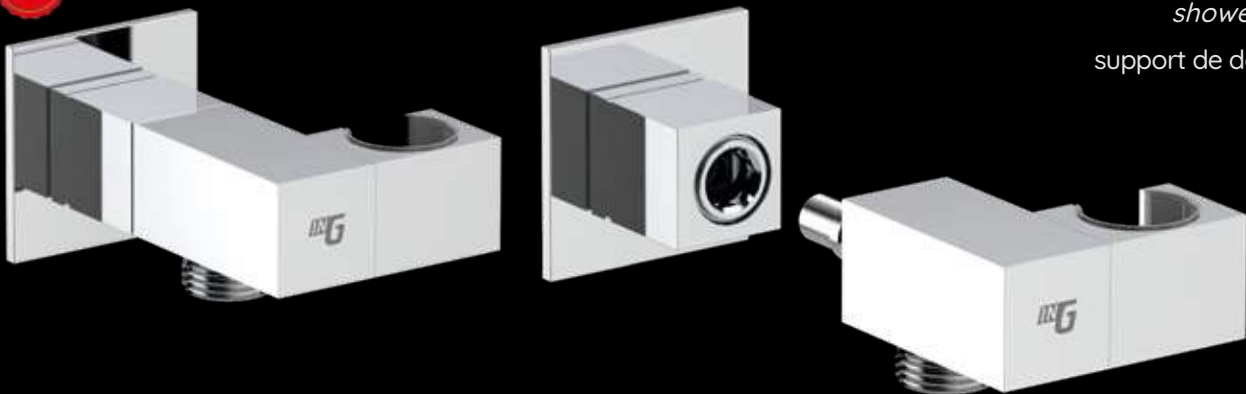

porta doccetta
shower holder
support de douche

Cod.	Note
IG705R	-
IG805S	-

IG705R

IG805S

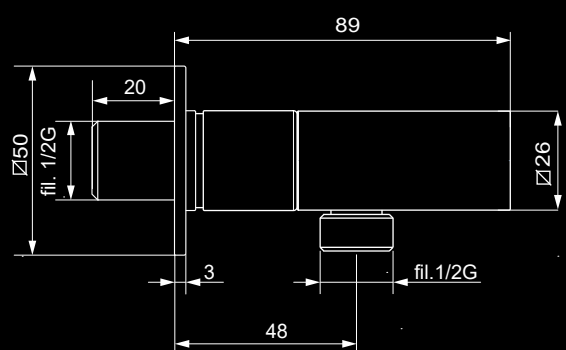
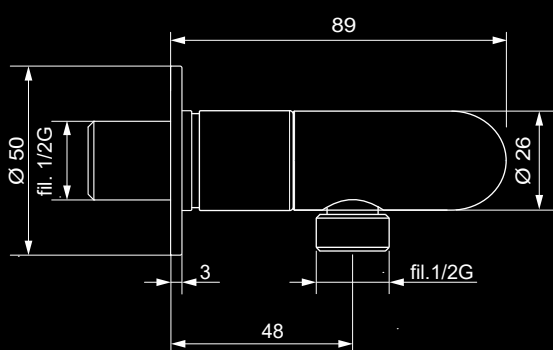

IG706R

INDOOR

NEW



Attacco rapido acqua MINIMAL in ottone cromato presa acqua con attacco flessibile 1/2" G

Brass chrome plated MINIMAL rapid fitting with 1/2" G shower hose connection

Raccord rapide MINIMAL en laiton chromé avec raccord pour flexible de douche 1/2" G



IDEALE PER
PERFECT FOR
IDÉAL POUR

IG806S

NEW



attacco flessibile
hose connection
raccord pour flexible

Cod.	Note
IG706R	-
IG806S	-

IG706R

IG806S

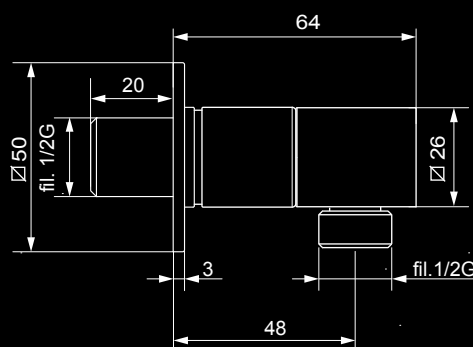
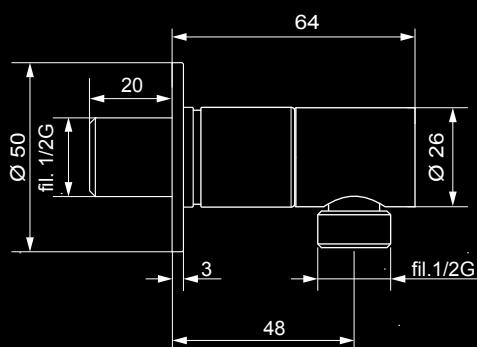



IT L'attenzione sull'ambiente bagno ad eventuali allagamenti o perdite d'acqua inaspettate è lo scopo principale del nostro sistema.

Le nostre prese SICURACQUA sono nate per salvaguardare la vita dei flessibili doccia (non adatti a rimanere in pressione).

L'obbligo della chiusura dell'acqua dopo l'utilizzo con un concetto di movimento naturale per riposizionare la doccetta nel supporto garantisce la tranquillità di un sistema sicuro

EN The main purpose of our system is the attention to the flooding or unexpected leakage of water in the bathroom environment.

Our SAFETY CLOSURE water supply is born to safeguard the shower hose life (they are not right remain in pressure).

The water closure obligation after use and the replacement of the handshower into the holder with a natural movement, is a guarantee of a security system.

FR Le but principal de notre système est de faire attention aux inondations ou aux fuites d'eau inattendues dans l'environnement de la salle de bain.

Notre alimentation en eau SICURACQUA est née pour sauvegarder la durée de vie des tuyaux de douchette (ils ne doivent pas rester sous pression).

L'obligation de fermeture de l'eau après utilisation et le remplacement de la douchette dans le support avec un mouvement naturel, est une garantie d'un système de sécurité.



01

Posizionando la doccetta nel supporto della presa l'acqua è chiusa

When the handshower is in the shower holder the water is closed

Lorsque la douchette est dans le support de douche, l'eau est fermée.



02

Estrarre la doccia e ruotare il supporto come un normale rubinetto

Take off the handshower and turn the shower holder as a normal tap

Retirez la douchette et tournez le support de douche comme un robinet normal



03

In questa posizione l'acqua viene aperta e pertanto si può utilizzare la doccetta pulsante

In this position the water is open and you can use the handshower

Dans cette position, l'eau est libre et vous pouvez utiliser la douchette



04

A fine utilizzo, per poter riposizionare la doccetta nel supporto, bisogna obbligatoriamente riportare lo stesso in posizione verticale chiudendo l'erogazione dell'acqua

After use, to put the handshower in the shower holder, you are obliged to close the water

Après utilisation, pour mettre la douchette dans le porte-douche, vous devez fermer le robinet d'eau



Attacco rapido acqua MINIMAL in ottone cromato a 2 vie con attacco flessibile 1/2" G e porta doccetta con chiusura SICURACQUA con protezione antigraffio

Brass chrome plated 2-way MINIMAL rapid fitting with 1/2" G shower hose connection and shower holder with scratch protection and SAFETY CLOSURE

Raccord rapide MINIMAL en laiton chromé à 2 voies avec raccord pour flexible de douche 1/2 "G et support de douche avec protection contre les griffes et fermeture de sécurité (SICURACQUA)



i CON - WITH - AVEC **SICURACQUA** **INFO** → pag. 33

IDEALE PER
PERFECT FOR
IDÉAL POUR

**porta idroscopino/doccetta per
connessione cassetta WC**

*hydrobrush/shower holder for
toilet box connection*

porte-douchette pour raccord
à la boîte de toilette

Cod.	Note
IG710R	Attacco 3/8" G e 1/2" G porta doccetta con vitone ceramico di chiusura - 3/8" G and 1/2" G connections shower holder with ceramic head - Greffe 2 voies 3/8" G et 1/2" G avec support douchette et ouvrage de tête à disque en céramique de fermeture

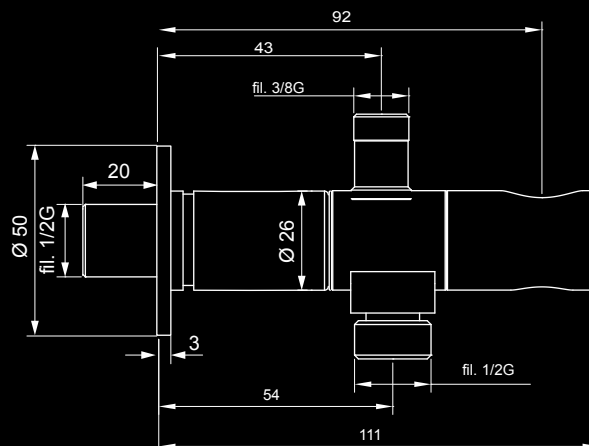



Attacco rapido acqua MINIMAL in ottone cromato con attacco flessibile 1/2" G e porta doccetta con chiusura SICURACQUA con protezione antigraffio

Brass chrome plated MINIMAL rapid fitting with 1/2" G shower hose connection and shower holder with scratch protection and SAFETY CLOSURE

Raccord rapide MINIMAL en laiton chromé avec raccord pour flexible de douche 1/2 "G et support de douche avec protection contre les griffes et fermeture de sécurité (SICURACQUA)



i CON - WITH - AVEC *SICURACQUA* **INFO** → pag. 33

**IDEALE PER
PERFECT FOR
IDÉAL POUR**

IG812S



**porta idroscopino/doccetta
hydrobrush/shower holder
porte-douchette**

i CON - WITH - AVEC *SICURACQUA* **INFO** → pag. 33

Cod.	Note
IG712R	Attacco 1/2" G porta doccetta con vitone ceramico di chiusura - 1/2" G connections shower holder with ceramic head - Greffe 1 voie 1/2" G avec support douchette et ouvrage de tête à disque en céramique de fermeture
IG812S	Attacco 1/2" G porta doccetta con vitone ceramico di chiusura - 1/2" G connections shower holder with ceramic head - Greffe 1 voie 1/2" G avec support douchette et ouvrage de tête à disque en céramique de fermeture

IG712R

IG812S

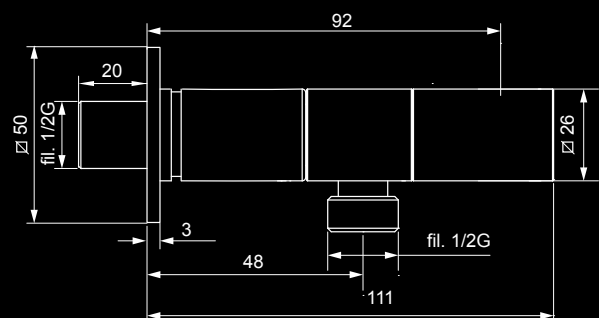
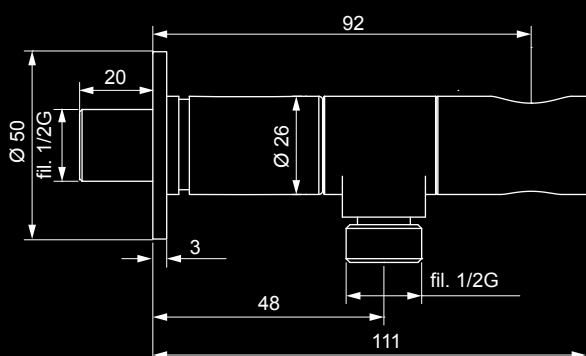



KIT SICURACQUA inGENIUS

INGENIUS SAFETY CLOSURE KIT

KIT FERMETURE DE SÉCURITÉ INGENIUS

INDOOOR

i CON - WITH - AVEC
SICURACQUA
INFO → pag. 33



Kit sicuracqua completo di doccia pulsante DUAL (2 getti) in ottone cromato + presa acqua 1 via con vitone di chiusura in ottone cromato + flessibile 1,20 Mt. D.A. 1/2" F cono gir. x 1/2" F cono gir. in ottone cromato

DUAL jets handshower safety closure set brass chrome plated + water elbow 1 way with safety closure brass chrome plated + shower hose double clamping 1,20 Mt. 1/2" F conical swivel x 1/2" F conical swivel

Kit sicuracqua complet de douchette avec bouton DUAL (2 jets) en laiton chromé + point de prise de l'eau 1 voie avec ouvrage de tête de fermeture en laiton chromé + flexible 1,20 Mt. D.A. 1/2" F cône pivotant x 1/2" F cône pivotant en laiton chromé



Finiture su richiesta
Finishing on request
Finitions sur demande



i CON - WITH - AVEC
SICURACQUA
INFO → pag. 33



Kit sicuracqua completo di doccia pulsante JEWEL (GETTO BIDET) in ottone cromato + presa acqua 1 via con vitone di chiusura in ottone cromato + flessibile 1,20 Mt. D.A. 1/2" F cono gir. x 1/2" F cono gir. in ottone cromato

JEWEL (BIDET JET) shut-off handshower safety closure brass chrome plated + water elbow 1 way with safety closure brass chrome plated + shower hose double clamping 1,20 Mt. 1/2" F conical swivel x 1/2" F conical swivel

Kit de douche complet Sicuracqua avec douchette JEWEL (BIDET JET) en laiton chromé + Prise d'eau à 1 voie en laiton chromé avec ouvrage de tête de fermeture + flexible 1,20 mt. D.A. 1/2" F cône pivotant x cône 1/2" F pivotant en laiton chromé

Getto disponibile
 Available jet
 Jet disponible

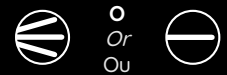

Finiture su richiesta
 Finishing on request
 Finitions sur demande





i CON - WITH - AVEC
SICURACQUA
INFO → pag. 33



Finiture su richiesta
Finishing on request
Finitions sur demande

Kit sicuracqua completo di doccia pulsante JEWEL IDROSCOPINO in ottone cromato + presa acqua 1 via con vitone di chiusura in ottone cromato + flessibile 1,20 Mt. D.A. 1/2" F cono gir. x 1/2" F cono gir. in ottone cromato

JEWEL (HYDROBRUSH JET) handshower safety closure set brass chrome plated + water elbow 1 way with safety closure brass chrome plated + shower hose double clamping 1,20 Mt. 1/2" F conical x 1/2" F conical swivel

Kit sicuracqua complet de douchette JEWEL (jet hydrobrosse) en laiton chromé + point de prise de l'eau 1 voie avec ouvrage de tête de fermeture en laiton chromé + flexible 1,20 Mt. D.A. 1/2" F cône x 1/2" F cône pivotant en laiton chromé

Getto disponibile
Available jet
Jet disponible

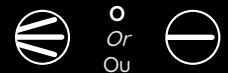



IG730R

Kit sicurezza completo di doccia pulsante DUAL (2 getti) in ottone cromato + presa acqua 2 vie con vitone di chiusura in ottone cromato + flessibile 1,20 Mt. D.A. 1/2" F cono gir. x 1/2" F cono gir. in ottone cromato

DUAL jets handshower safety closure set brass chrome plated + water elbow 2 way with safety closure brass chrome plated + shower hose double clamping 1,20 Mt. 1/2" F conical swivel x 1/2" F conical swivel

Dual 2 jets Shut-off en laiton chrome + sortie eau 2 voies avec ouvrage de tête de fermeture en laiton chromé + flexible 1,20 Mt. D.A. 1/2" F cône pivotant x 1/2" F cône pivotant en laiton chrome

IG718R

Kit sicurezza completo di doccia pulsante JEWEL "(Getto bidet)" in ottone cromato + presa acqua 2 vie con vitone di chiusura in ottone cromato + flessibile 1,20 Mt. D.A. 1/2" F cono gir. x 1/2" F cono gir. in ottone cromato

JEWEL handshower safety closure set brass chrome plated + water elbow 2 way with safety closure brass chrome plated + shower hose double clamping 1,20 Mt. 1/2" F conical swivel x 1/2" F conical swivel

JEWEL Shut-off en laiton chrome + sortie eau 2 voies avec ouvrage de tête de fermeture en laiton chromé + flexible 1,20 Mt. D.A. 1/2" F cône pivotant x 1/2" F cône pivotant en laiton chrome

IG723R

Kit sicurezza completo di doccia pulsante AXIS "Idroscopino" in ottone cromato + presa acqua 2 vie con vitone di chiusura in ottone cromato + flessibile 1,20 Mt. D.A. 1/2" F cono gir. x 1/2" F cono gir. in ottone cromato

AXIS "Hydrobrush" handshower safety closure set brass chrome plated + water elbow 2 way with safety closure brass chrome plated + shower hose double clamping 1,20 Mt. 1/2" F conical swivel x 1/2" F conical swivel

AXIS "Hydrobrosse" Shut-off en laiton chrome + sortie eau 2 voies avec ouvrage de tête de fermeture en laiton chromé + flexible 1,20 Mt. D.A. 1/2" F cône pivotant x 1/2" F cône pivotant en laiton chrome



i CON - WITH - AVEC
SICURACQUA
INFO → pag. 33



Getto disponibile
Available jet
Jet disponible



o
Or
Ou



DISEGNI TECNICI KIT
KIT TECHNICAL DRAWINGS
DESSINS TECHNIQUES DES KITS

IG718R

pag. 43

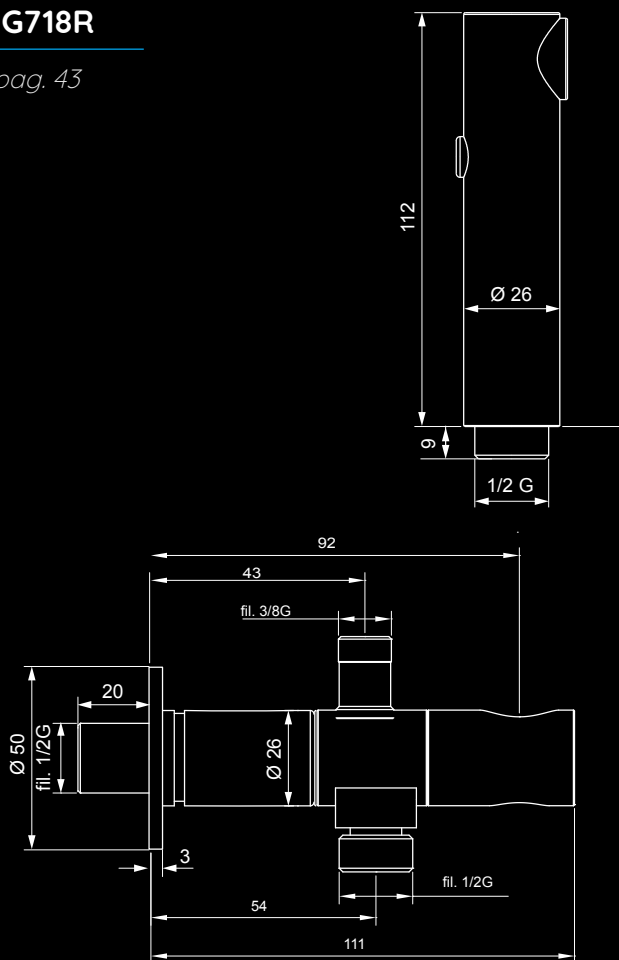

IG720R

pag. 39

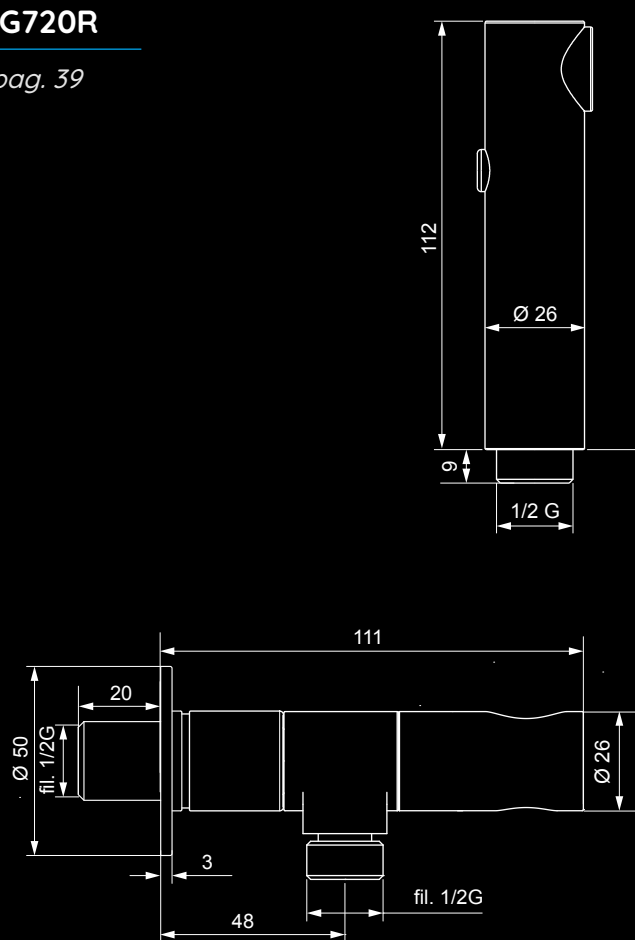

IG723R

pag. 43

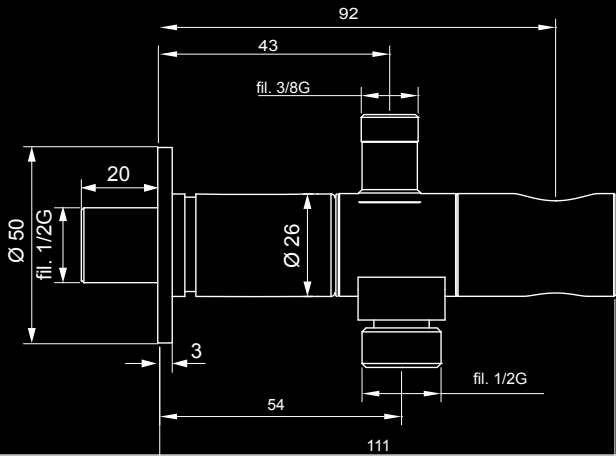
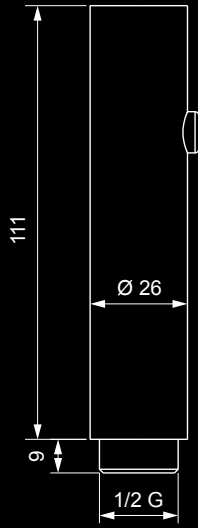

IG725R

pag. 41

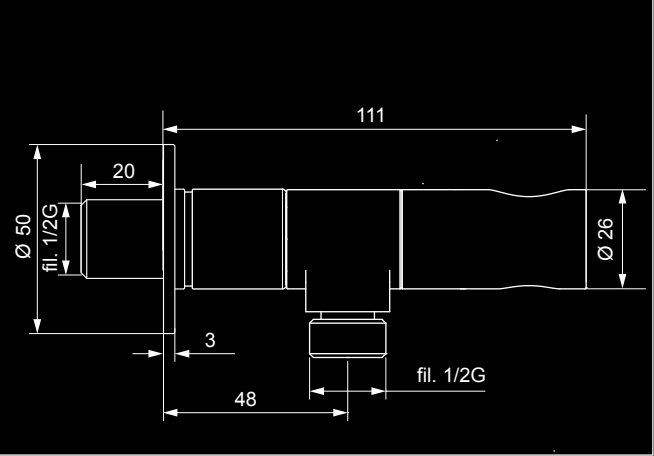
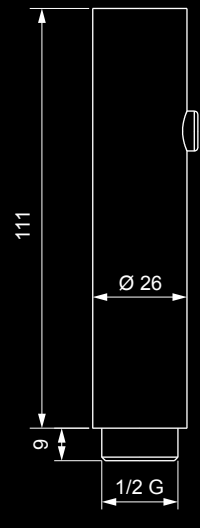

IG730R

pag. 43

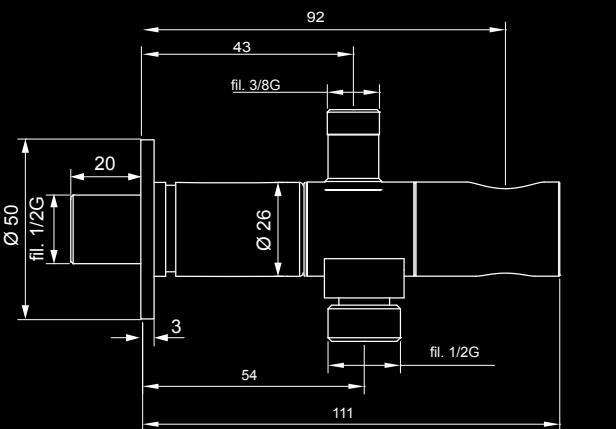
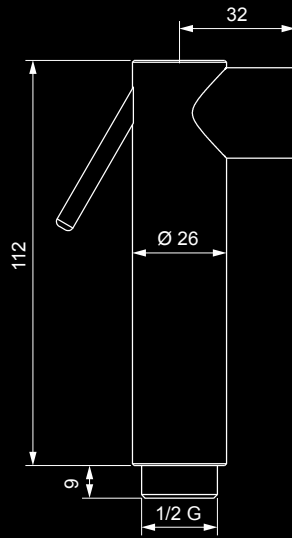

IG732R

pag. 37

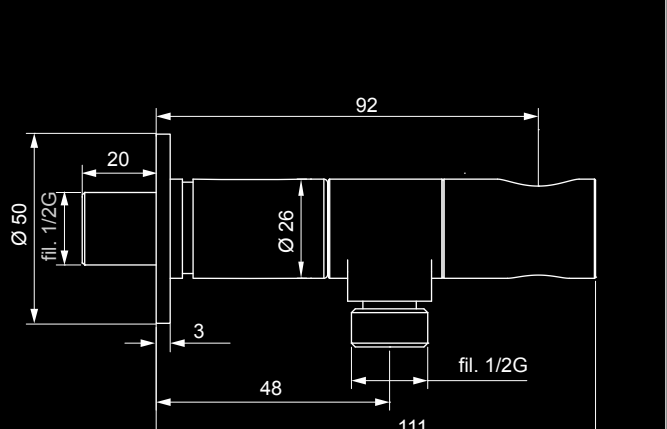
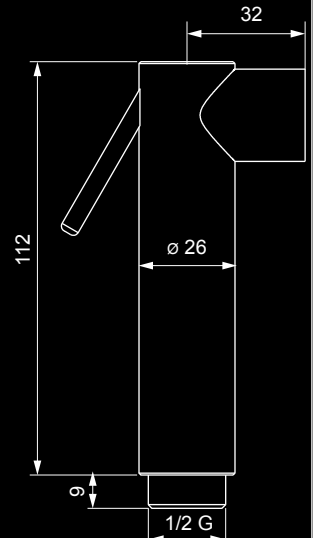

IG820R

pag. 39

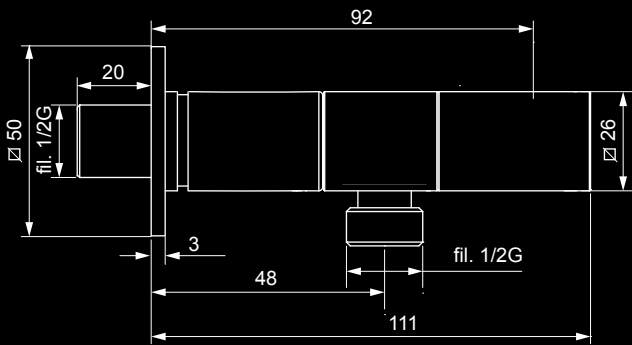
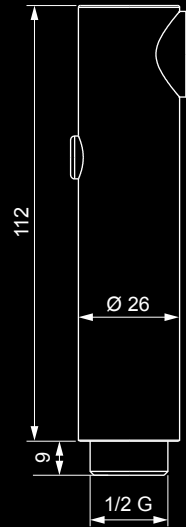

IG832R

pag. 37

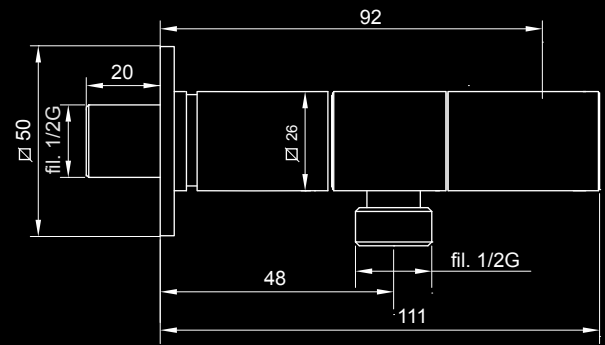
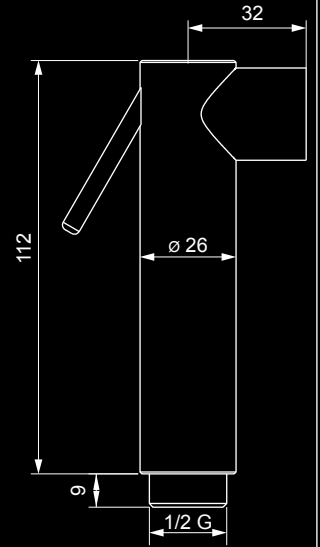

IG825S

pag. 41

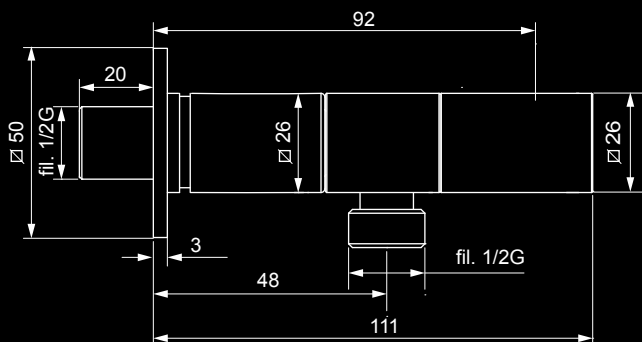
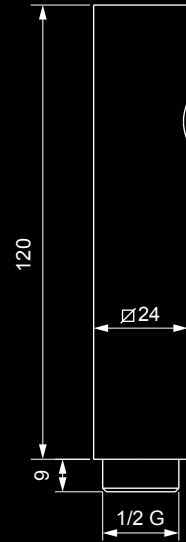

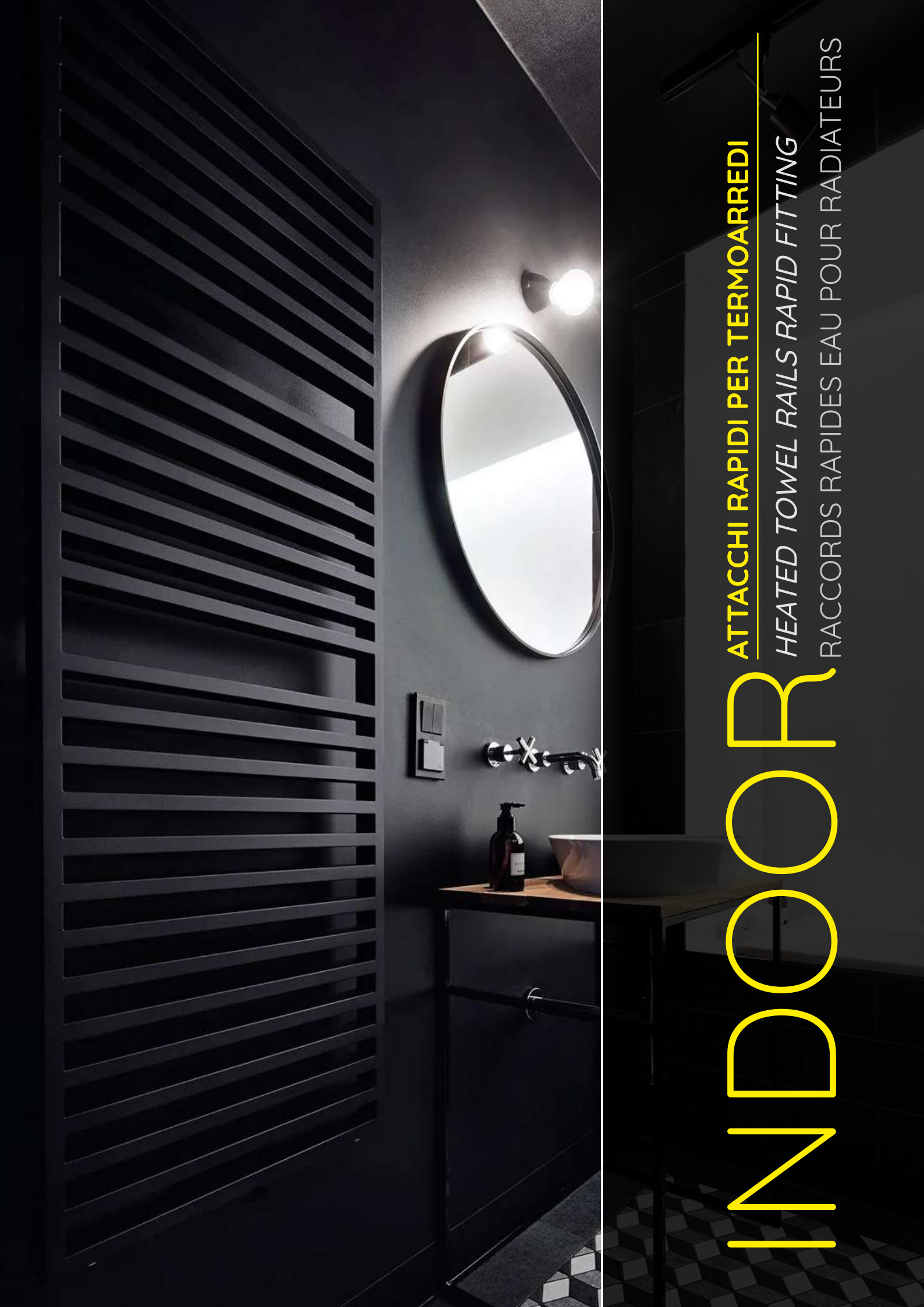

ATTACCHI RAPIDI PER TERMOARREDI

HEATED TOWEL RAILS RAPID FITTING

RACCORDS RAPIDES EAU POUR RADIATEURS

INDOOR



ACCESSORI SPECIFICI ANCHE PER INSTALLAZIONE TERMOARREDI MEDIANTE CONNESSIONE CON TUBO MULTISTRATO O TUBO PEX

SPECIFIC ACCESSORIES FOR DECORATIVE RADIATOR INSTALLATION BY CONNECTION WITH MULTILAYER PIPE OR PEX PIPE

ACCESSOIRES SPÉCIFIQUES POUR INSTALLATION RADIATEURS AVEC BRANCHEMENT TUYAU MULTICOUCHES OU PEX.

Valvola inGENIUS con attacco 1/2" - 3/4" per adattatori multistrato e tubo PEX a stringere

inGENIUS valve with 1/2" - 3/4" connection for multilayer pipe adapter and PEX pipe adapter to tighten

Vanne inGENIUS avec raccord 1/2" - 3/4" pour adaptateurs multicouches et tuyau PEX à serrer.

IG012 (1/2) IG013 (3/4)

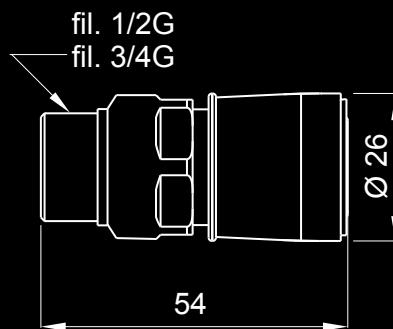
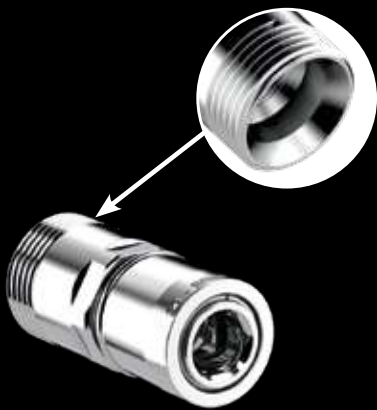

IN ABBINAMENTO - IN COMBINATION - EN COMBINAISON AVEC

Cod.	Note
7010	Adattatore multistrato con ogiva e calotta nichelata - Adapter with Nickel-Plated nut and ring for multilayer pipe - Adaptateur multicouches avec ogive et calotte nickelée
7030	Adattatore PEX con ogiva e calotta nichelata - Adapter with Nickel-Plated nut and ring for PEX pipe - Adaptateur PEX avec ogive et calotte nickelée



SG7010

cod.	size	box
SG7010014002N	14x2	10
SG7010016002N	16x2	10
SG7010016E02N	16x2 (*)	10
SG7010016225N	16x2,25	10
SG7010018002N	18x2 (*)	10
SG7010020002N	20x2 (*)	10
SG7010020225N	20x2,25 (*)	10
SG7010020250N	20x2,5 (*)	10



SG7030

cod.	size	box
SG7030016002G	16x2	10
SG7030016220G	16x2,2	10
SG7030016002E	16x2 (*)	10
SG7030016220E	16x2,2 (*)	10
SG7030018002G	18x2 (*)	10
SG7030018250G	18x2,5 (*)	10
SG7030020002G	20x2 (*)	10
SG7030020280G	20x2,8 (*)	10

(*) Attacco 3/4" Eurocono - (*) Junction 3/4 Eurocone - (*) Raccord 3/4" Eurocône

RACCORDI - FITTINGS - RACCORDS

INNESTI CONSIGLIATI PER INSTALLAZIONE TERMOARREDI

RECOMMENDED FITTINGS FOR HEATED TOWEL RAIL INSTALLATION

GREFFES RECOMMANDÉS POUR INSTALLATION RADIATEURS



IG900U-1/2G

Raccordo in ottone cromato da 1/2\"G
Brass chrome plated rapid fitting 1/2\"G
 Greffe 1/2\"G pour inUNICA by inGENIUS



IG900U-3/4G

Raccordo in ottone cromato da 3/4\"G
Brass chrome plated rapid fitting 3/4\"G
 Greffe 3/4\"G pour inUNICA by inGENIUS



IG920UE

Raccordo in ottone cromato 3/4\"G maschio eccentrico
Brass chrome plated rapid fitting 3/4\"G male eccentric connector
 Greffe 3/8\"G - 1/2\"G - 3/4\"G pour inUNICA by inGENIUS



IG922UE

Raccordo 1/2\"G femmina in ottone cromato calotta eccentrica SWISS
Brass chrome plated rapid fitting 1/2\"G female SWISS eccentric cap
 Greffe 1/2\"G Fem. calotte excentrique SWISS inUNICA by inGENIUS



IG923UE

Raccordo 3/4\"G femmina in ottone cromato calotta fissa SWISS
Brass chrome plated 3/4\"G female rapid fitting SWISS fixed cap
 Greffe 3/4\"G Fem. calotte excentrique SWISS inUNICA by inGENIUS



IG924UF

Raccordo da 1/2\"G femmina calotta fissa inUNICA by inGENIUS
Brass chrome plated 1/2\"G female rapid fitting SWISS fixed cap
 Greffe 1/2\"G Fem. calotte fixe SWISS inUNICA by inGENIUS



IG925UF

Raccordo da 3/4\"G femmina calotta fissa inUNICA by inGENIUS
Brass chrome plated 3/4\"G female rapid fitting SWISS fixed cap
 Greffe 3/4\"G Fem. calotte fixe SWISS inUNICA by inGENIUS



**IG903URDA
 IG903URGA**

Attacco rapido TONDO in ottone cromato 1 via 3/4\"G e 1/2\"G per connessione doccia con vitone ceramico
1 way ROUND brass chrome plated rapid fitting 3/4\"G and 1/2\"G for handshower connection with headwork ceramic valve
 Greffe raccord rapide avec robinet et raccordement 1/2\"G - 3/4\"G inUNICA by inGENIUS

ATTENZIONE - ATTENTION - ATTENTION



IG015R

Possibilità di usare i nostri rosoni telescopici
Possibility to use our telescopic rosettes
 Possibilité de combiner nos rosaces télescopiques

TEST SUI PEZZI
TEST ON THE PIECES
TEST SUR LES PRODUITS

PROVA DI TENUTA STATICA

COMPONENTE IN PROVA: Raccordo rapido in Genius
 PRODUTTORE: S.G. Via Roma 5, Maurizio d'Opaglio (Na)
 ATTREZZATURA DI PROVA: Banco prova Idraulico
 MANOMETRO CAMPIONE: Bit 02 0-1000 bar

Esecuzione prova con pressione statica incrementata gradualmente sino al valore di scoppio
 Temperatura ambiente: 20 ±5 °C - Temperatura acqua: 20 ±5 °C

REF.	Componente	P. scoppio (bar)	Note
002	Raccordo InGenius	745	prova eseguita con acqua a T ambiente salita in pressione graduale

Esito: **positivo**: il valore della pressione di scoppio è nettamente superiore al valore limite
normalmente definito quattro volte superiore alla pressione massima operativa

Allegati: **report di prova del manometro**

Date: 5/12/2013 Operatore: Alberto Giussani

La strumentazione utilizzata per le prove è provvista di dichiarazioni di collaudo con riferibilità ai campioni primari Accredia. PAG. 2/2



GIUSSANI S.r.l.
 Via del Credito, 411 - 80045 Fara Serra d'Adda (BG) - ITALY
 Tel. 0363 999028 - Fax 0363 998725
 Internet: www.giussanonline.it
 E-mail: info@giussanonline.it

PROVE DI TENUTA A PRESSIONE PULSANTE

pulsing pressure test

Component under test: raccordo rapido in Genius da 1/2" Gas
 Manufacturer: S.G. Via Roma 5, Maurizio d'Opaglio (Na)
 Test bench: Test Bench with acquisition System

Test description: pressione cycles from P1=5 to P2= 50 con frequenza di 1 Hz
 Temperatura ambiente: 20 ± 2 °C - Water Temperature 15 ± 2 °C

REF.	Component	N° CYCLES	Note
001	raccordo rapido	100+100+100	Sequence of 3 test cycles
002	raccordo rapido	100+100+100	Sequence of 3 test cycles
002	raccordo rapido con inserto inserito	100+100+100	Sequence of 3 test cycles

Result: **positive** no leaks during the test
 Note: The component N° 2 has been tested at max. pressure up to the burst limit at 745 bar
 attached: test reports

Date: 5/12/2013 Operatore: Alberto Giussani

The instrumentation used for the test is with calibration reports with reference to official national standard ACCREDIA. PAG. 2/2



GIUSSANI S.r.l.
 Via del Credito, 411 - 80045 Fara Serra d'Adda (BG) - ITALY
 Tel. 0363 999028 - Fax 0363 998725
 Internet: www.giussanonline.it
 E-mail: info@giussanonline.it

CERTIFICAZIONE DEI MATERIALI
CERTIFICATION OF MATERIALS
CERTIFICATIONS DES MATÉRIELS



Certificazioni ottenute in fase di collaudo riguardanti: normativa italiana DM174/04 e attestazione di conformità sanitaria francese ACS, certificato di conformità SASO.

Certifications obtained during the testing phase on: DM italian law 174/04 and attestation of conformity French health ACS, certificate of conformity SASO.

Certifications obtenues en phase d'essai concernant: réglementation italienne DM174/04 et attestation de la conformité sanitaire française ACS, certificat de conformité SASO



www.sistemaingenius.it
info@sistemaingenius.it



Via Roma 135/B - 28017 San Maurizio D'Opaglio (Novara) Italia
ph. +39 0322 967249 - +39 0322 967789
www.sg-srl.com - info@sg-srl.com